



ISG>PACK
AUTOMATIC PACKAGING SYSTEM

Nastratrici per scatole

CARTON SEALERS



CORNER TAPE 50 TBB – 50A TBB

 220 VOLTS



Nastratrice automatica disponibile nella versione a dimensionamento manuale della scatola (Corner tape 50 TBB) o autodimensionante (Corner Tape 50A TBB). La caratteristica principale di questa macchina è quella di nastrare automaticamente i lati superiori ed inferiori della scatola applicando 4 strisce di autoadesivo ad "U". La scatola viene trasportata da una rulliera motorizzata verso uno spintore pneumatico che la direziona (con una rotazione di 90° rispetto all'inserimento) verso le quattro teste nastranti. A nastratura completata la scatola continua il percorso verso un sistema di cilindri ad aria che completano l'operazione abbassando i lembi del nastro e sigillando ermeticamente il pacco su tutti i lati. Possibilità di inserimento in linee automatiche non presidiate da operatori.



Automatic carton sealer available in the version with manual box dimensioning (Corner tape 50 TBB) or self-dimensioning (Corner Tape 50A TBB). The main feature of this machine is that it automatically tapes the upper and lower edges of the box by applying 4 "U" strips of adhesive tape. The box is transported by a motorized roller conveyor to a pneumatic pusher that diverts it to 90° of its original position and feeds it towards the four taping heads. Once the taping is completed, the box feeds to an air cylinder system that lowers the edges of the tape and hermetically seals the package on all sides. Possibility to put the machine in a fully automatic line without operator.

 Macchine con dimensioni a richiesta
Customized machines on request

 Assenza dell'operatore
Without operator

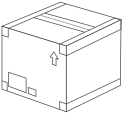
 Nastratura ai 4 angoli
4 Edge sealing

 Disponibile in acciaio Inox
Stainless steel version
CORNER TAPE 50 TBB SS
CORNER TAPE 50A TBB SS

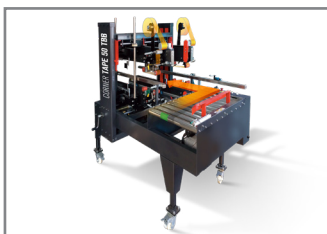
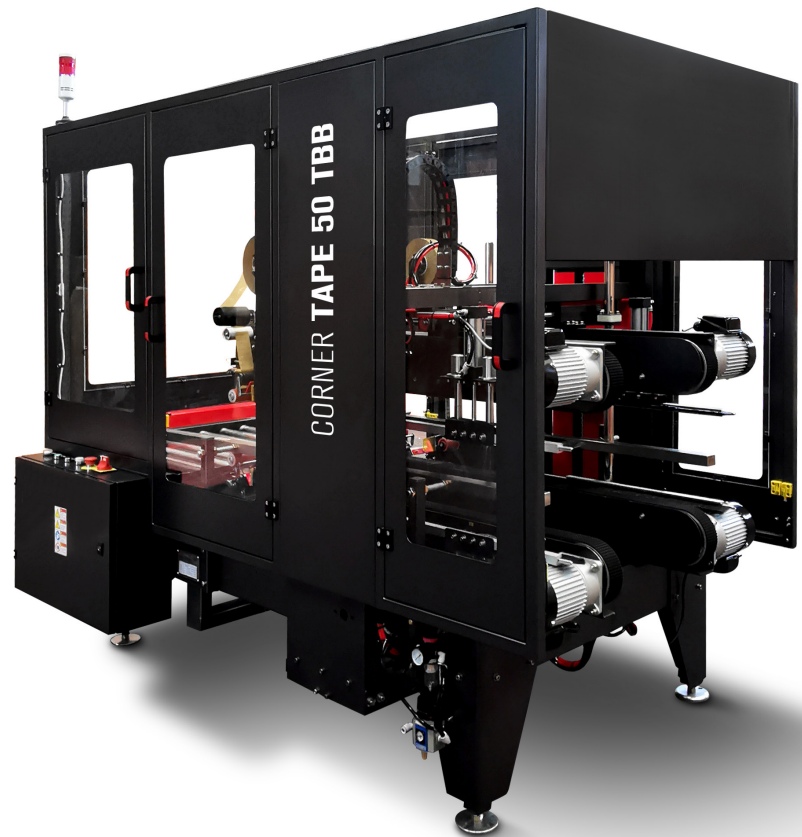

PARTICOLARE MACCHINA
MACHINE DETAIL



DISPLAY TOUCH SCREEN DA 7,2" A COLORI
DIGITAL COLOR TOUCH SCREEN 7,2"



MACCHINA GESTITA DA PLC
MACHINE CONTROLLED BY PLC

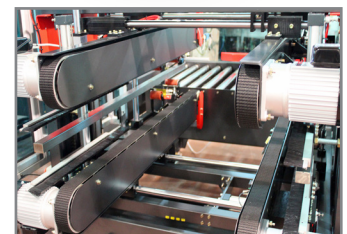

QUATTRO TESTE DI NASTRATURA
FOUR TAPING HEADS

Caratteristiche tecniche

- ⊕ Peso: 480 Kg
- ⊕ Alimentazione elettrica: 220 Volts - 50 / 60 Hz
- ⊕ Velocità di trasferimento scatola: 19 mt / min
- ⊕ Pressione aria: 6 kgf / cm²
- ⊕ **Versione autodimensionante (Corner Tape 50A TBB)**
- ⊕ **Versione manuale (Corner Tape 50 TBB)**
- ⊕ Consumo aria: 11 Nltri / min
- ⊕ Peso max scatola: 30 Kg
- ⊕ Dimensioni macchina: L 2168 x W 1373 x H 1335 - 1485 mm
- ⊕ Fungo di emergenza per le normative CE
- ⊕ Nastro adesivo: Kraft, Polipropilene, PVC
- ⊕ Altezza piano lavoro: 600 - 750 mm

Technical details

- ⊕ **Weight: 480 kg**
- ⊕ **Power supply: 220 Volts - 50 / 60 Hz**
- ⊕ **Box transfer speed: 19 mt / min**
- ⊕ **Air pressure: 6 kgf / cm²**
- ⊕ **Self-dimensioning version (Corner Tape 50A TBB)**
- ⊕ **Manual version (Corner Tape 50 TBB)**
- ⊕ **Air consumption: 11 Nlitr / min**
- ⊕ **Maximum box weight: 30 kg**
- ⊕ **Machine dimensions: L 2168 x W 1373 x H 1335 - 1485 mm**
- ⊕ **Emergency stop in compliance with CE regulations**
- ⊕ **Adhesive tape: Kraft, Polypropylene, PVC**
- ⊕ **Working table height: 600 - 750 mm**

	DIMENSIONI SCATOLE BOX DIMENSION	
	MINIMO MIN	MASSIMO MAX
LUNGHEZZA LENGTH	340 mm	670 mm
LARGHEZZA WIDTH	200 mm	470 mm
ALTEZZA HEIGHT	200 mm	500 mm

	NASTRO ADESIVO ADHESIVE TAPE	
	TIPO TYPE	MASSIMO MAX
50 mm	PP PVC KRAFT	990 mt
75 mm	PP PVC KRAFT	990 mt
-	-	-

LAYOUT

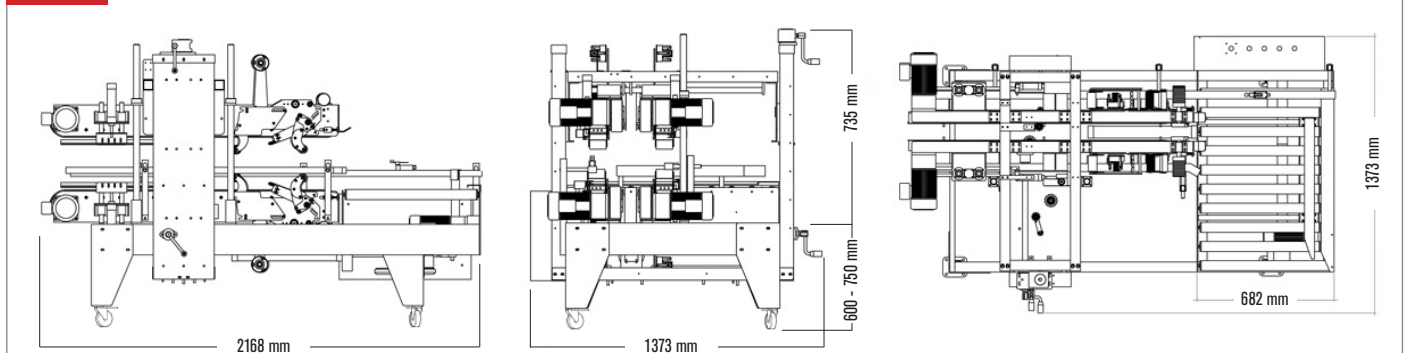

DATI TECNICI | DATA SHEET

	CORNER TAPE 50 TBB	CORNER TAPE 50A TBB
Alimentazione elettrica Power supply	220 volts - 1 ph - 50 / 60 Hz	220 volts - 1 ph - 50 / 60 Hz
Potenza Installata Installed power	1 kW	1 kW
Pressione aria Air pressure	6 bar	6 bar
Consumo aria Air consumption	11 Nltri / min 11 Nlitr / min	11 Nltri / min 11 Nlitr / min
Velocità nastratura Sealing speed	Fino a 4 / 6 scatole min Up to 4 / 6 boxes min	Fino a 4 / 6 scatole min Up to 4 / 6 boxes min
Testa nastrante Taping head	50 - 75 mm	50 - 75 mm
Dimensionamento scatola Box sizing	Manuale Manual	Autodimensionante Self-dimensioning

CARATTERISTICHE PRODOTTO LAVORABILE | PRODUCT FEATURES

Dimensioni min. scatole Min box dimension	L 340 x W 200 x H 200 mm	L 340 x W 200 x H 200 mm
Dimensioni max. scatole Max box dimension	L 670 x W 470 x H 500 mm	L 670 x W 470 x H 500 mm
Tipologia di scatole Box type	Scatole di tipo americano American type boxes	Scatole di tipo americano American type boxes

ISG>PACK
AUTOMATIC PACKAGING SYSTEM

🌐 www.isg-pack.com @ info@imballaggiservice.com

Via Castelli Romani Km. 11,700 | Angolo Via Sassuolo, 6
00071 Pomezia | Roma | Italy
T. +39.06.9160.7561 | F. +39.06.9162.5014

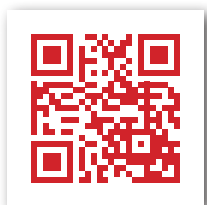

VISITA IL SITO WEB

