



**ISG>PACK**  
AUTOMATIC PACKAGING SYSTEM

## Nastratrici per scatole

CARTON SEALERS



# RANDOM TAPE 50 TBB



Nastratrice semiautomatica autodimensionante con quattro cinghie di trascinamento, due superiori e due inferiori, che sigilla con nastro autoadesivo la parte superiore ed inferiore di scatole a formato variabile. Questa nastratrice è particolarmente indicata per scatole alte e corte, instabili o pesanti. L'operatore sromba la scatola, ne piega le falde inferiori, la inserisce nel gruppo centratore per poter riempire la scatola senza doverla tenere con le mani ed abbassa le falde superiori. Successivamente la spinge in macchina, facendo attivare il finecorsa del gruppo della testa superiore, il quale scende fino all'altezza della scatola stessa. Durante il passaggio in macchina la scatola viene nastrata simultaneamente sopra e sotto. Compresa di rulliera centratore in ingresso, rulliera in uscita e ruote, costituisce una semplice e pratica postazione di imballaggio.

Semi-automatic and self-dimensioning carton sealer with four feeding belts, two top and two bottom which seal the top and the bottom of variable size boxes with adhesive tape. This carton sealer is particularly suited for tall or unstable boxes. The operator squares the box, folds the bottom flaps, inserts it in the centering/holding unit where the box can be filled without having to keep it with his hands, folds the top flaps. Thereafter, he guides it into the machine which activates the microswitch of the upper taping head which falls to the top the box. While the boxes pass through the machine, the top and the bottom flaps will be sealed by the taping heads simultaneously. Machine includes infeed center rollers, outfeed rollers and wheels, representing a practical and simple packaging station.

 **Macchine con dimensioni a richiesta**  
Customized machines on request

 **Presenza dell'operatore**  
With operator

 **Nastratura superiore/inferiore**  
Top/bottom sealing

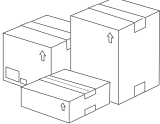
 **Cartoni di vario formato**  
Variable carton sizes

 **Disponibile in acciaio Inox**  
Stainless steel version  
**RANDOM TAPE 50 TBB SS**



**Sistema brevettato per cambio rapido nastro adesivo**  
Patented system for quick change of adhesive tape



**PARTICOLARE PNEUMATICO**  
PNEUMATIC DETAIL



**INTERRUTTORE GENERALE**  
MAIN POWER SWITCH



**RUOTE DI SERIE**  
WHEELS INCLUDED



**CINGHIE DI TRASCINAMENTO**  
FEEDING BELTS

## Caratteristiche tecniche

- ⊕ Peso: 220 Kg
- ⊕ Alimentazione elettrica: 220 Volts - 50 / 60 Hz
- ⊕ Velocità di trasferimento scatola: 22 mt / min
- ⊕ **Cinghie superiori motorizzate**
- ⊕ Pressione aria: 6 kgf / cm<sup>2</sup>
- ⊕ Peso max scatola: 30 Kg
- ⊕ Dimensioni macchina: L 1961 x W 960 x H 1373 -1673 mm
- ⊕ Rumorosità max: ≤ 75 db
- ⊕ Fungo di emergenza per le normative CE
- ⊕ Nastro adesivo: Kraft, Polipropilene, PVC
- ⊕ Testa nastrante standard: 50 - 75 mm
- ⊕ Altezza piano lavoro: 580 - 830 mm

## Technical details

- ⊕ **Weight: 220 Kg**
- ⊕ **Power supply: 220 Volts - 50 / 60 Hz**
- ⊕ **Box transfer speed: 22 mt / min**
- ⊕ **Power top belts**
- ⊕ **Air pressure: 6 kgf / cm<sup>2</sup>**
- ⊕ **Maximum box weight: 30 kg**
- ⊕ **Machine dimensions: L1961 x W 960 x H 1373 -1673 mm**
- ⊕ **Maximum Noise: ≤ 75 db**
- ⊕ **Emergency stop in compliance with CE regulations**
- ⊕ **Adhesive Tape: Kraft, Polypropylene, PVC**
- ⊕ **Standard taping head: 50 - 75 mm**
- ⊕ **Working table height: 580 - 830 mm**

	DIMENSIONI SCATOLE BOX DIMENSION	
	MINIMO   MIN	MASSIMO   MAX
LUNGHEZZA   LENGTH	150 mm	∞
LARGHEZZA   WIDTH	200 mm	580 mm
ALTEZZA   HEIGHT	170 mm	600 mm

	NASTRO ADESIVO ADHESIVE TAPE	
	TIPO   TYPE	MASSIMO   MAX
50 mm	PP   PVC   KRAFT	990 mt
75 mm	PP   PVC   KRAFT	990 mt
-	-	-

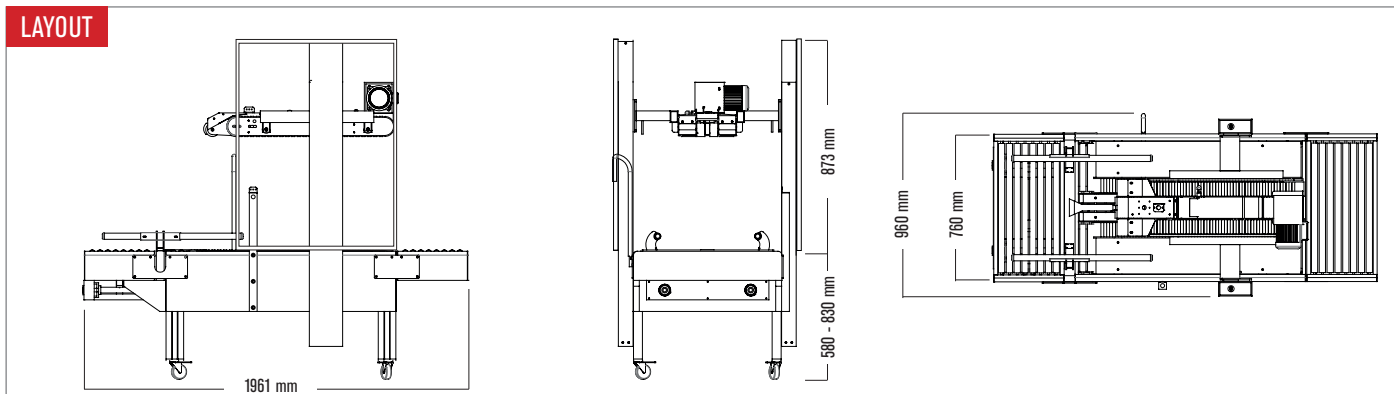

### DATI TECNICI | DATA SHEET

Alimentazione elettrica | Power supply

Potenza Installata | Installed power

Pressione aria | Air pressure

Consumo aria | Air consumption

Velocità nastratura | Sealing speed

Testa nastrante | Taping head

### RANDOM TAPE 50 TBB

220 volts - 1 ph - 50 / 60 Hz

0,60 kW

6 bar

33.3 Nlitri / min | 33.3 Nliter / min

Fino a 15 scatole min | Up to 15 boxes min

50 - 75 mm

### CARATTERISTICHE PRODOTTO LAVORABILE | PRODUCT FEATURES

Dimensioni min. scatola | Min box dimension

Dimensioni max. scatola | Max box dimension

Tipologia di scatole | Box type

L 150 x W 200 x H 170 mm

L ∞ x W 580 x H 600 mm

Scatole di tipo americano | American type boxes

**ISG>PACK**  
AUTOMATIC PACKAGING SYSTEM

🌐 [www.isg-pack.com](http://www.isg-pack.com) @ [info@imballaggiservice.com](mailto:info@imballaggiservice.com)

Via Castelli Romani Km. 11,700 | Angolo Via Sassuolo, 6  
00071 Pomezia | Roma | Italy  
T. +39.06.9160.7561 | F. +39.06.9162.5014

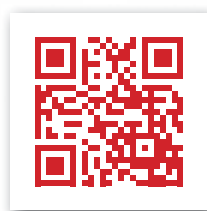

VISITA IL SITO WEB

